

MATERIALS

Retaining wall units shall be Versa-lok Square Foot block units as manufactured by Kirchner Block & Brick. The units are 18" wide x 8" tall x 12" deep with a split face finish. The color shall be chosen by the owner. Concrete wall units shall meet the requirements of ASTM C1372 except compressive strength shall be a minimum 3000 psi and the maximum water absorption shall be limited to 8.0 percent. The concrete shall have adequate freeze thaw resistance in accordance with ASTM C1262.

The reinforced wall backfill material shall be compacted rock and soil. The rock shall be well graded crushed limestone with a maximum 2" particle size and a maximum of 10% passing the #200 sieve, similar to 2" minus gradation. The soil shall be free of organics, free of rocks and clumps larger than 4", and have a PI<20 and a LL<40.

The geogrids shall be Miragrid 2XT and 3XT geogrid as indicated on the plans and as manufactured by TC Mirafi Group. The geotextile filter fabric shall be Mirafi 140NL.

The leveling pad shall be constructed of crushed limestone similar to 1" or 2" minus rock gradation.

The drainage rock shall be a free draining material such as 3/4" clean crushed limestone.

The drainage pipe shall be 4" HDPE tubing.

WALL FOUNDATION

Foundation soil shall be excavated as required for the leveling pad and the reinforced fill zone to the depths and locations shown on the plan sheet or as directed by the site engineer. The exposed foundation soil shall be observed by the project soils engineer prior to construction to verify that the exposed material is suitable for a net allowable bearing pressure of 2000 psf (with a factor of safety of 2.0), and that the base of the excavation is free of loose soil, shale, high plastic clays, uncompacted fill, water, or frozen material. Undercut areas shall be filled with crushed limestone and compacted to at least 95% of the material's standard Proctor maximum dry density.

The foundation shall be proof rolled with 2 passes of a vibratory compactor prior to beginning wall construction.

Construct the crushed rock leveling pad to lines and grades shown on the plans. The leveling pad shall be compacted in a maximum 6" lifts with 3 passes of a vibratory compactor.

WALL CONSTRUCTION

Install the first course of units on the leveling pad. Install the next course in a running bond stack. Blocks may need to be cut to maintain the running bond. The units shall overlap the units below by a minimum of 4". Place the Versa-luf pin through the top unit holes and into the slot in the unit below. Use a minimum of 2 pins per units. Pull unit forward. Backfill units and continue construction.

Install drainage rock in unit cores and extending 12" behind wall units.

Cap units shall be glued in place at the top of the wall.

GEOGRID REINFORCING

The geogrids shall be cut to design lengths and placed between the blocks at the elevations shown on the plans. The geogrid's primary strength direction will be directed perpendicular to the wall face (into the fill.) The geogrids placed outside a plus or minus 4" zone of the geogrid design elevation will not be accepted. The geogrid shall be placed horizontally and lay flat on the reinforced fill soil. The geogrid shall be placed so that a minimum of 8" of grid is between the block layers. Slack in the geogrid shall be removed prior to placing additional backfill.

WALL BACKFILL

Wall backfill material shall be placed in maximum 8" loose lifts and compacted to at least 95% of the material's maximum dry density as determined by the standard Proctor method (ASTM D698.) Backfill shall be placed, spread, and compacted in such a manner that minimizes wrinkles and movement of the geogrid. Field density testing shall be conducted by a qualified soils technician to verify that at least the minimum degree of compaction is being obtained. The drainage rock shall be compacted with a minimum 2 passes of a vibratory compactor and field density testing will not be required.

During backfill placement the 3 foot zone directly behind the wall shall be limited to the use of hand operated compaction equipment only.

Construction equipment shall not be operated directly on the geogrid.

FENCE

The fence posts shall be grouted into Sonotubes or PVC pipe sleeves. The sleeves shall be installed into the backfill during wall construction. The backfill shall be compacted around the sleeves. The geogrids shall be cut around the sleeves as necessary.

PROTECTION OF WORK

The surface of the wall backfill shall be graded at the end of each day of work to provide positive surface drainage away from the wall. Grading shall include proper contouring of soils in adjacent areas to prevent the flow of surface water into the reinforced earth zone and to prevent to flow of surface water along the front face of the wall.

The designs of the walls are based on conditions and loads imposed on the wall at completion of the project. Prior to project completion, the wall is vulnerable to damages caused by construction activity adjacent to the wall. Of particular concern is the use of grading and pavement construction equipment on the retained backfill at the top of the wall. Only equipment with a weight not exceeding one ton can be used in the 3 foot zone directly behind the back of the wall face.

No changes shall be made to these plans without the written approval of Aspen Consultants.

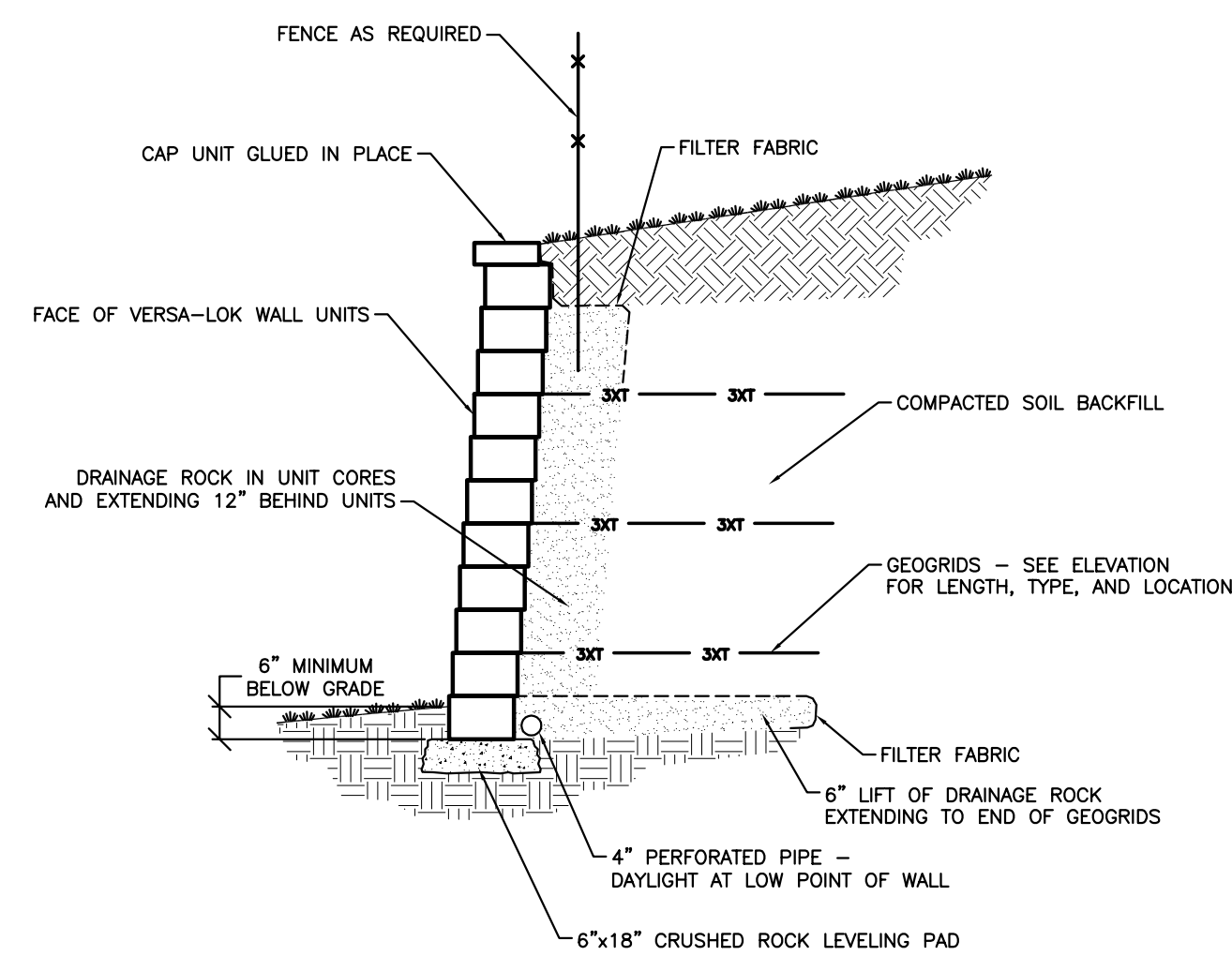

TYPICAL SECTION
NOT TO SCALE

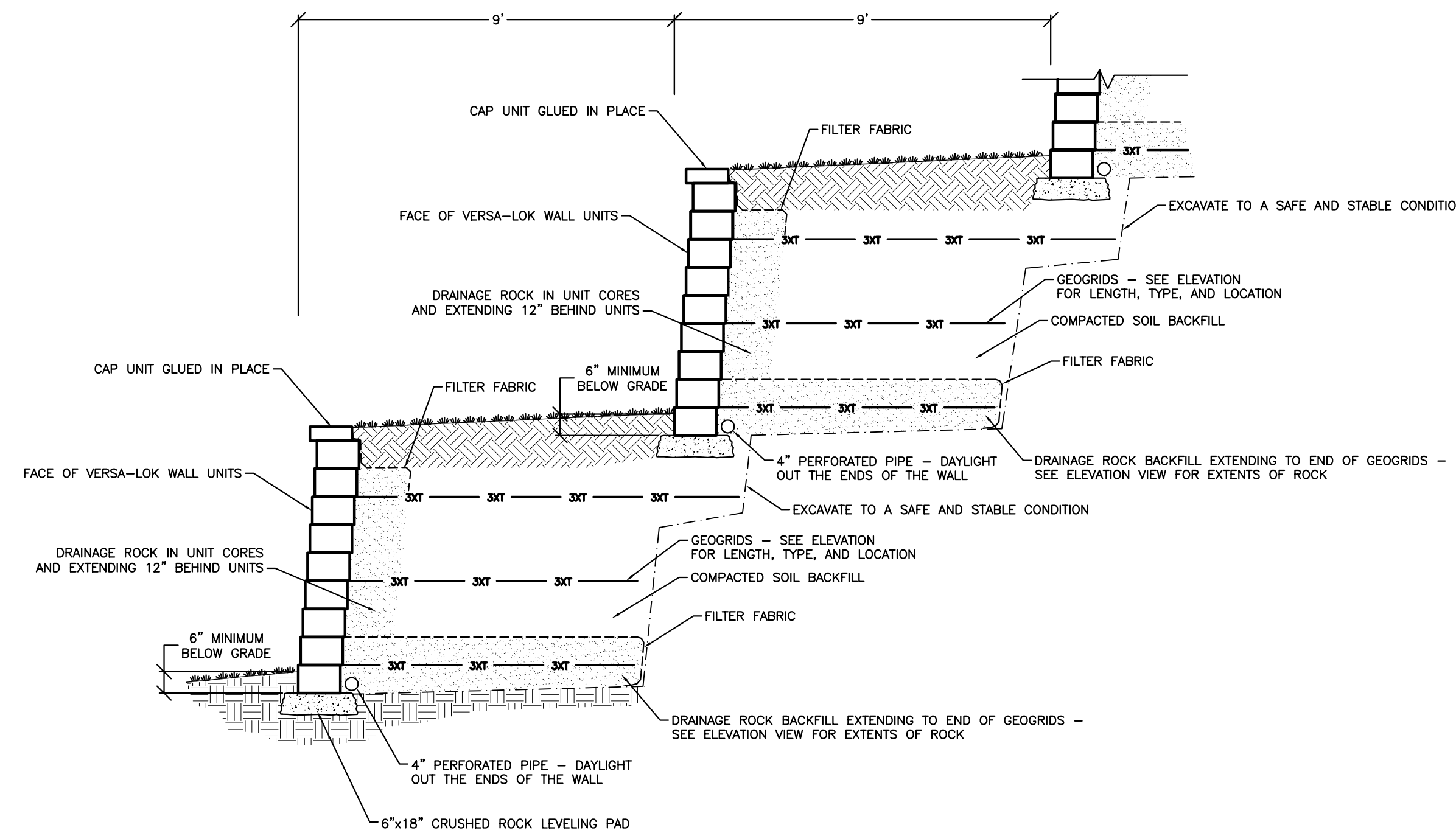

WALLS RT1 - RT4
NOT TO SCALE

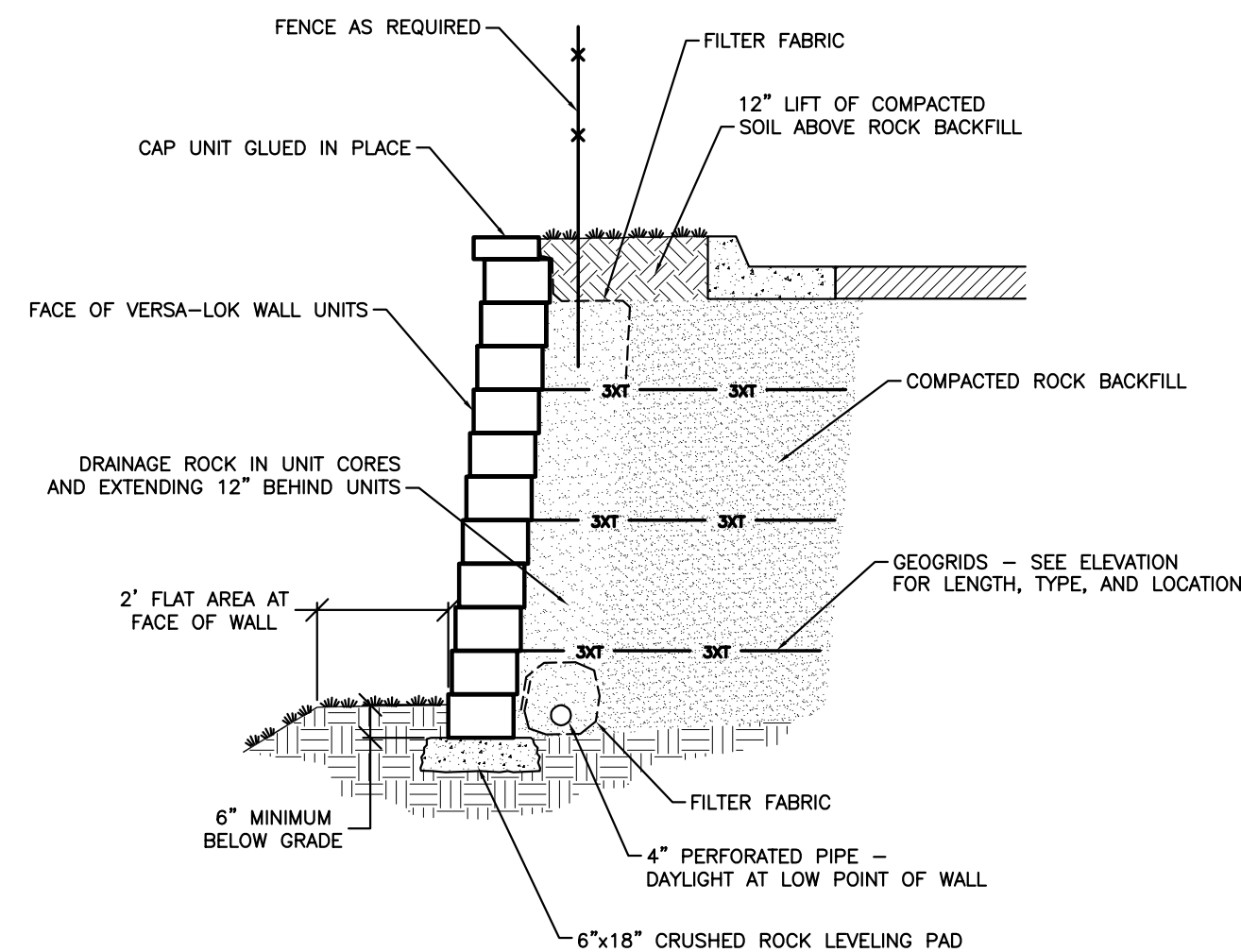

WALLS RT7 & RT8
NOT TO SCALE

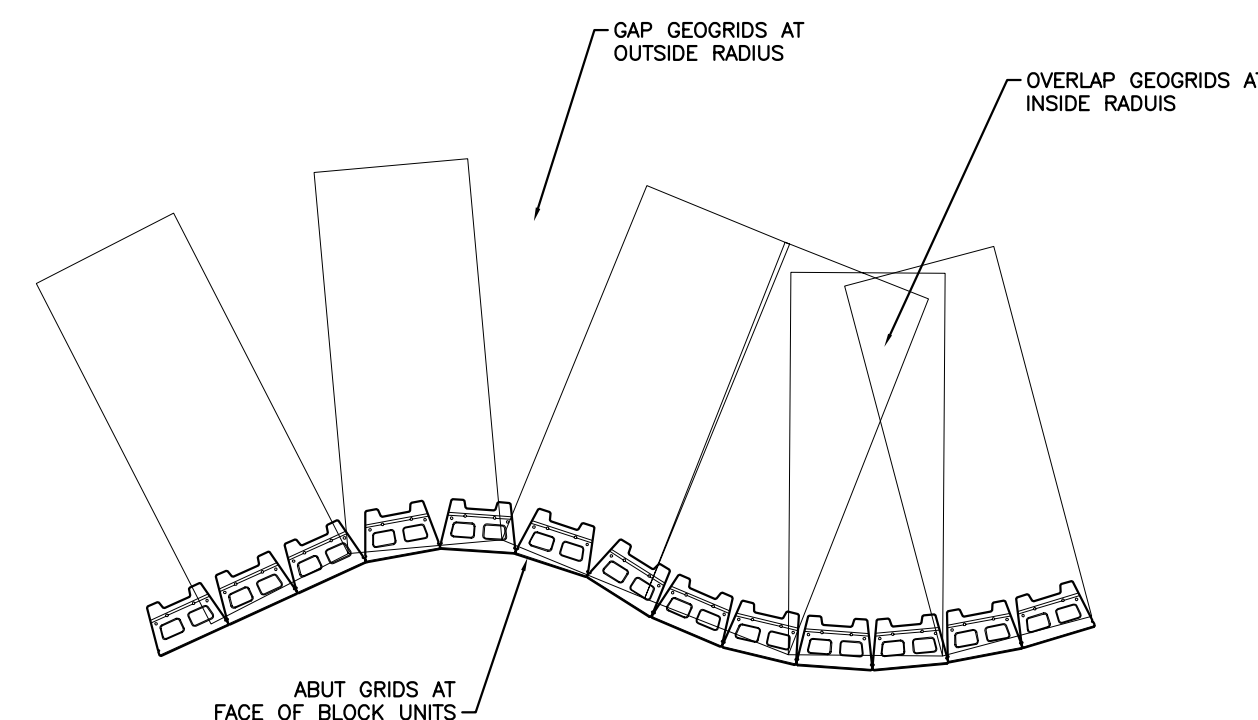

RADIUS DETAIL
NOT TO SCALE

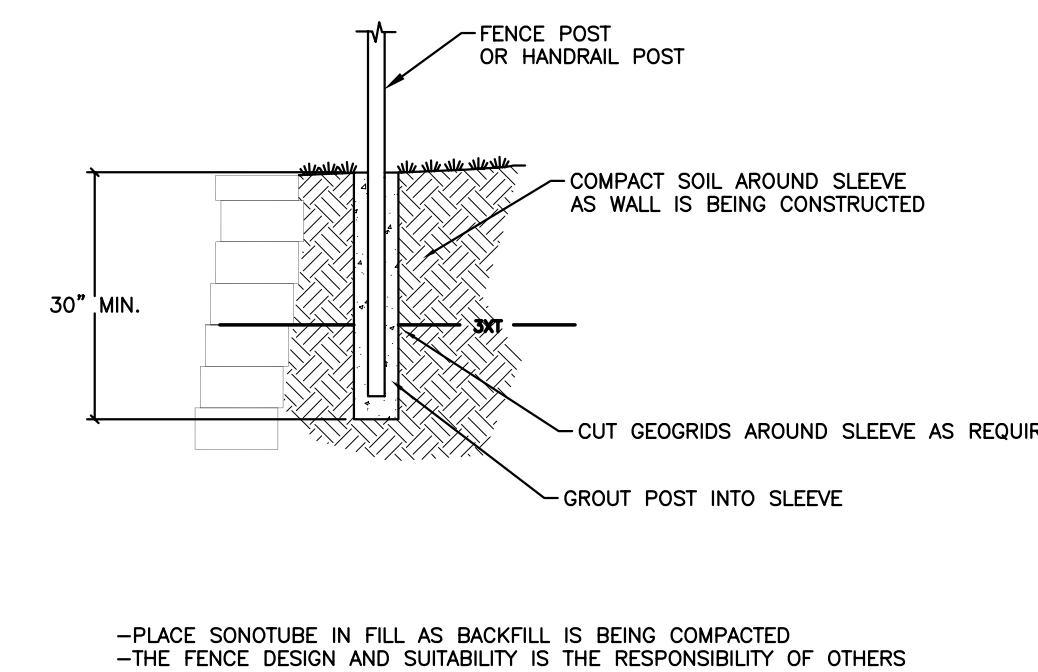

FENCE DETAIL
NOT TO SCALE

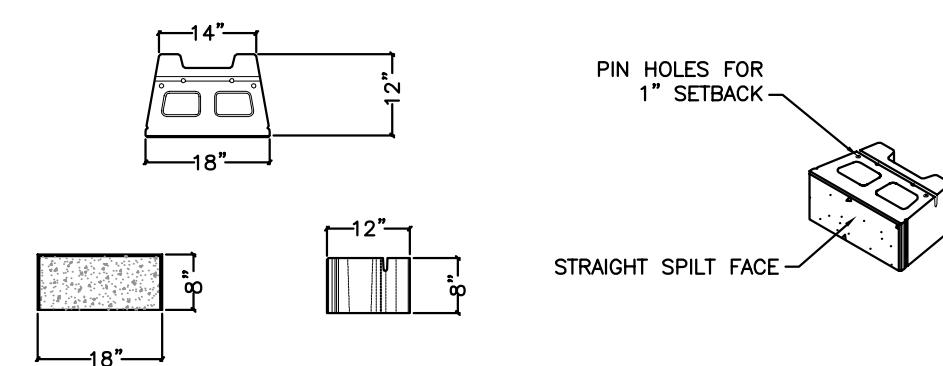

VERSA-LOK SQUARE FOOT UNIT
NOT TO SCALE

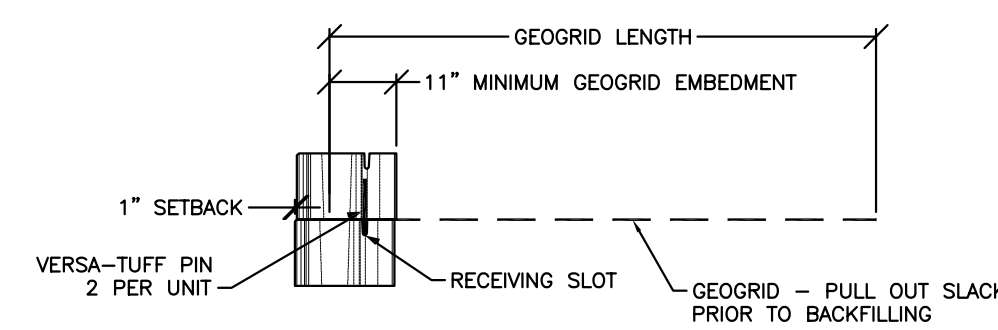

CONNECTION DETAIL
NOT TO SCALE

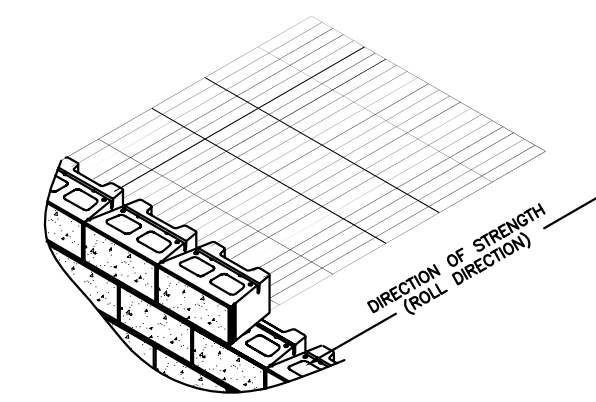

293 Northwest Blvd., Fenton, MO 63026
Phone: (636) 349-2225 Fax: (636) 349-2230

COLUMBIA MIDDLE SCHOOL
Columbia, IL

VERSA-LOK WALL | DETAILS AND SPECS

Revision: | Date: 5-14-2004

Revision: | Sheet: 6 of 6